

MATV
MARQUETTE-ADAMS TELEVISION

ADB SET TOP BOX

REMOTE

USER'S GUIDE

PROVIDING VIDEO/DSL THROUGH YOUR PHONE LINE

Your telephone line is upgraded to allow voice, data & video transmission simultaneously. It is called Triple Play. A DSL Modem is installed to receive the video signal via a CAT-5 telephone wire. There will have to be a cat 5 wire ran from the protector on the outside of the house to the modem location (wherever that may be as every house has a different situation). Then from the modem there will be either cat 5 ran to each TV location from the modem or in the instance where there is already coax ran in the correct way and it's the correct kind of coax we can use that. In the event where we use the coax, a converter box can be used. Converter boxes convert the Ethernet signal to coax at the modem end and convert it back to Ethernet at the TV location. One other way for us to get the video signal to your STB is wireless. We are the only TV service in the industry that can send the signal via wireless equipment. From the Modem, the video signal is dispersed to a Set Top Box. Each television to receive the video signal will have its own Set Top Box and Remote and can view video transmission independently. The modem is the brains behind the TV service. The modem communicates with office and sends the signal to the STB's. STB stands for *SET TOP BOX*. When the modem isn't connected with our office correctly it may cause your service to be interrupted.

In order for MATV service to work, a specific channel or video input is required. Most often the TV will be on channel 3. In some cases your TV will be on a VIDEO INPUT, such as input 1 or 2 or whatever it is. Your technician will tell you what channel or input your TV must be on to watch our service. In some cases (where applicable) the installer may run the audio/video cables through your VCR/DVD player. We do this to ensure you have the best video and sound quality. If we do run it through the VCR/DVD player it will have to stay powered on in order for it to send the signal to your TV.

So now you have some information on how our service works. Let's move into how to use it. In the next pages we will describe how to change channels, work with the settings, and use to guide and some troubleshooting for some basic problems.

HOW TO USE THE REMOTE AFTER YOU'VE PROGRAMMED IT

Each STB comes with its own remote control. Though the remote will control any STB it will only control the particular TV it goes with (depending if we were able to program it to your TV).

Because the universal remote can control several different components, it uses operational modes triggered by the component buttons.

For example, if you want the remote to control the TV, press the TV button to put the remote into TV mode. If you want to control the STB then push the STB button. If you are in the TV mode you will be able to turn the TV on and off but, may not be able to change the channels or do anything with the STB.

Here's an example of how you would start from the beginning. Grab the remote and push TV. Then push the pwr button. This will turn your TV on. Once your TV is on and you are on the correct channel or input then push the STB button. This changes the mode in the remote to now control the STB.

Note:

The remote may not be compatible with all brands and models of components. It also may not operate all functions of the remote that came with your component.

If you keep pressing buttons and nothing happens, the remote is probably in the wrong mode. You must press the component button that matches the component you want to operate.

YOUR VIDEO SYSTEM WORKS ON A HIGHLIGHT & SELECT METHOD

Use the arrow keys on the remote to highlight an option on your screen, and then press OK/Select on the remote to choose that option.

THE REMOTE CONTINUED

As was stated before each STB comes with its own remote. The remote will control all STB's but only the TV it goes with. The next few pages are a little info about your new remote.

Please see the info on the remotes on the next few pages. They will tell you how to try and program our remote to your TV. However there are some TV's that may not program to control the TV's power on and off and the volume. There is also some general info on how the remote works and functions of some of the buttons.

CHANGING CHANNELS

Once the TV is on, press the STB button. The remote is now in the STB mode and will change channels on our service. Using the channel + and – button you will be able to change channels one at a time up or down. Because of it being a digital signal it takes a couple of seconds for the channel to display.

The up and down arrow keys located around the OK button are call the navigation buttons. They can be use to scroll up and down in the channel order, without changing the channel. Once you have something on the banner at the bottom of the page you can simply push the OK button and you will go to that channel. By pushing the up or down arrow once it will bring up the blue banner on the bottom, displaying info such and the time, description of the show or event, and other info concerning the channel. Now you can simply go up or down the channel order and push the OK when you get to something you want to watch.



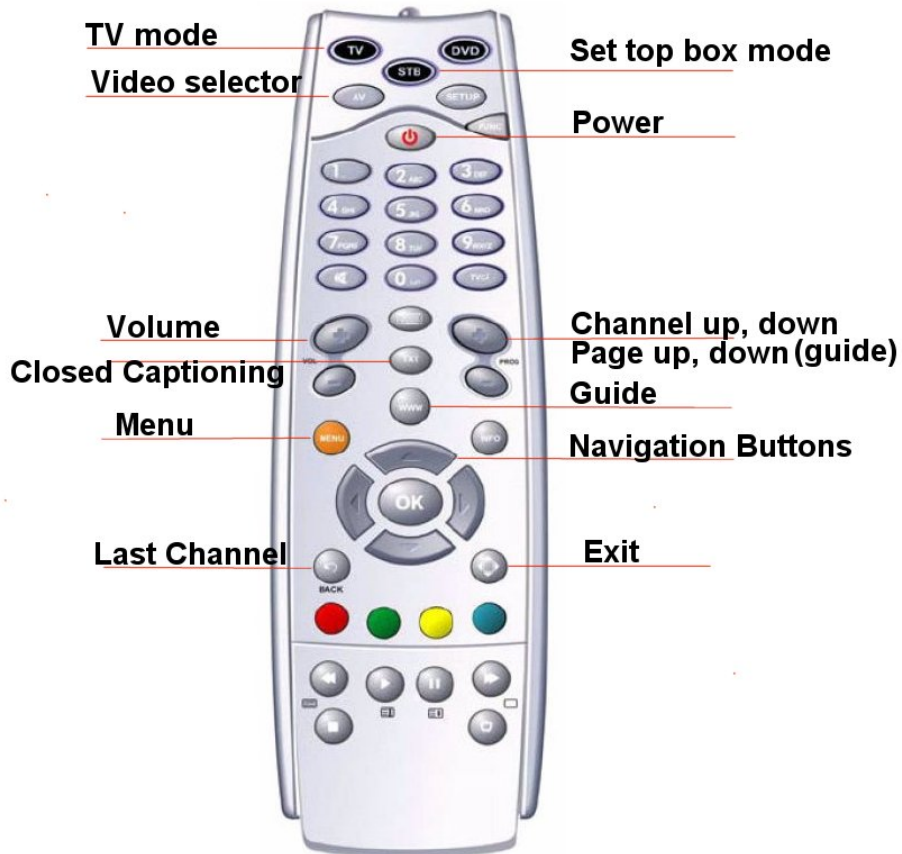









THE REMOTE



















Here is a little illustration of the remote and some of the main functions. Please use this as a guide to assist you in learning how to use it.

The next few pages are some more info on the remote. The first ones are a little more info about the STB and on the buttons and the functions of them; the next few are the info on how to program the remote to your TV.

ADB 3800W Remote with Minerva Middleware

BUTTON	Minerva Command	Minerva Key Map	Minerva Description
	SV		<Not Mapped>
	SETUP	123	
	POWER	116	Toggle standby mode on the set top box
	SHIFT		<Not Mapped>
	1	2	Number 1
	2	3	Number 2
	3	4	Number 3
	4	5	Number 4
	5	6	Number 5
	6	7	Number 6
	7	8	Number 7
	8	9	Number 8
	9	10	Number 9
	0	11	Number 10
	VKBD	95	(Note: Virtual Keyboard)
	TXT		<Not Mapped>
	ACTION	67	Electronic Program Guide
	MENU	88	Minerva TOP MENU
	INFO	59	Program Information
	VOLUME UP	115	<Not Mapped>
	VOLUME DOWN	114	<Not Mapped>
	CHANNEL UP	104	Next Channel
	CHANNEL DOWN	109	Previous Channel
	UP	103	Navigation UP

ADB 3800W Remote with Minerva Middleware

BUTTON	Minerva Command	Minerva Key Map	Minerva Description
	DOWN	108	Navigation DOWN
	LEFT	105	Navigation LEFT
	RIGHT	106	Navigation RIGHT
	OK	87	Navigation SELECT
	BACK	68	Return
	EXIT (Scroll)	70	(Note: Button above the BLUE Button)
	RED	63	(Note: Go Back - when in hardware settings.)
	GREEN	64	
	YELLOW	65	(Note: This key is blocked from the Minerva Application.)
	BLUE	66	(Note: Confirm - when in hardware settings.)
	REWIND	55	VOD Rewind
	PLAY	102	VOD Plan
	PAUSE	119	VOD Pause
	FAST FORWARD	98	VOD Fast Forward
	STOP	110	VOD Stop
	TV	61	(Note: Bottom Left Button)

3800W

LEDs and Display

The LED indicators inform you about the status of your decoder.
Display presents current time.

USB slot

USB slot allows you to connect external devices.

Function buttons

These buttons perform the same function as the correspondent ones on the remote control.



Included Accessories

As you unpack your digital decoder, please make sure that the following accessories are included:



Getting Started



Remote Control

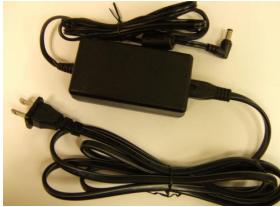

Power Adaptor



Cables



Batteries

Rear Panel

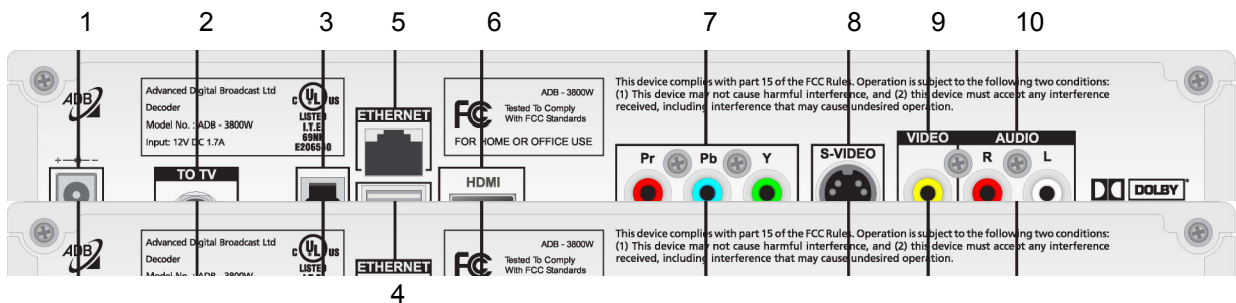

1 - Power plug (12V)

2 - Output to TV

3 - S/PDIF (Digital Audio Output)

4 - USB port

5 - Ethernet port

6 - HDMI (HD Digital Output)

7 - Component Output (HD Analog Output)

8 - S-VIDEO Output

9 - CVBS VIDEO Output

10 - RCA Stereo Audio Output

Connectivity Diagrams

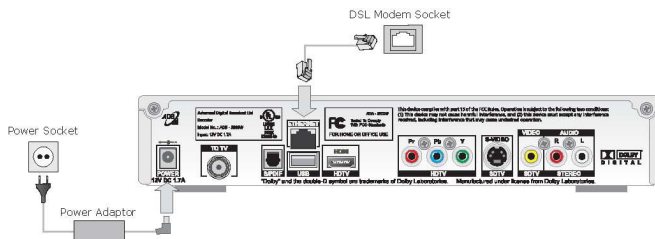

Basic connection

These are mandatory connections for each decoder to operate properly. Connect power supply via Power Adaptor. Next connect Ethernet port with the DSL Modem socket using ethernet cable.

TV connections

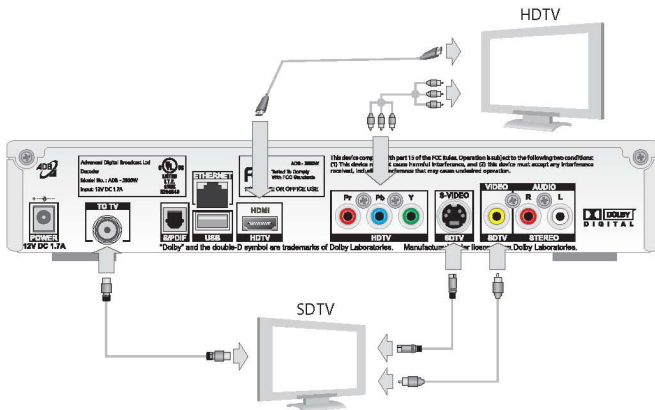

Choose **one** of the available types of connections of your decoder with the TV set. Keep in mind that HDMI and YPbPr connectors are for HDTV and other connectors for SDTV.

Note: F-connector type applies to TV out. It cannot be connected to other cable distribution system, such as cable TV network, satellite dishes, receiving antennas etc.

Audio connections

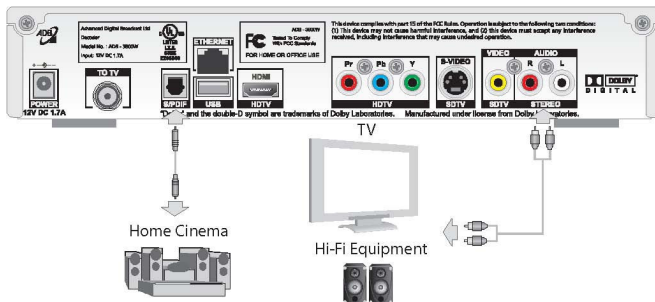

Choose **one** of the three types of audio connections available.

If you have a Home Cinema you can connect it to your decoder using S/PDIF connector and an appropriate cable.

To use your Hi-Fi Equipment you need to connect it to the audio output of your decoder using RCA cable.

VCR, DVD Recorder connections

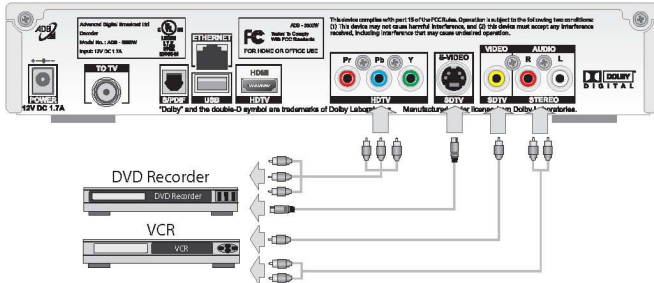

As an option you can connect your decoder to your VCR or DVD Recorder to record programs. Choose **one** of the two possible connections.

Note: To record sound you need to connect your DVD or VCR to the audio output of your decoder using RCA cable.

Remote Control

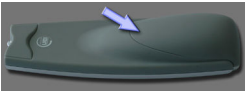

To change the batteries, you have to open the cover on the back of the remote. Press the cover gently as indicated on the left.

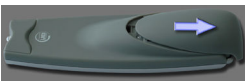

Next, slide the cover off as shown on the left. Other ways of opening the cover may result in breaking the remote control.

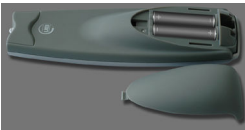

The batteries should be installed observing the polarity in the way presented on the left.

Remote Control Programming Instructions

Setting up the FOCUS 3-MODE

Example: To set up the FOCUS 3-MODE for your television:

- 1. Make sure your device (television) you wish to operate is switched on** (not in standby).
- 2. Find the code for your device in the Code List (page xx -xx).** The device codes are listed per device type and brand name. Also the most popular code for each brand is listed first (**Note: If your brand is not listed at all, try the Search Method below**)
- 3. Press the device mode key (e.g. TV)** on the Focus remote for the device you wish to set up.
- 4. Press and hold down SHIFT** until the red light blinks twice (the red light will blink once then twice).
- 5. Enter your four-digit device code** using the number keys. The red light will blink twice.
- 6. Now aim the FOCUS 3-MODE remote at your device (television) and press POWER.** If your device switched off, the FOCUS 3-MODE is ready to operate your device.

-Most TV's do not switch back on pressing the POWER key, please try pressing a "number" key or the "TV-text off" key to switch your TV back on. -If your device does not respond, follow steps 1 through 6 with each code listed for your brand. If none of the codes listed for your brand operate your device, then try the Search Method described below, even if your brand is not listed at all. -Some codes are quite similar. If your device does not respond or is not functioning properly with one of the codes, try another code listed under your brand. -If the original remote control from your Video Recorder / DVD player did not have a POWER key, press PLAY instead of POWER during step 6. -To set up your other devices, follow the same instructions above, only press the appropriate device key during step 3. -Remember to press the correct device key before operating your device. Only one device can be assigned to a device key.

-Write your device code in the applicable four digit boxes provided in the battery compartment and on page 8 for future reference.

Step and Set Search Method

- ➔ If your device does not respond to the FOCUS 3-MODE after you have tried all the codes listed for your brand.
- ➔ --> If your brand is not listed at all, the Search Method allows you to scan through all the codes contained in the memory of the FOCUS 3-MODE.

Example: To search for your television code:

1. Switch your television on (not in standby mode).
2. Press the **TV** key on the FOCUS 3-MODE.
3. Press and hold down SHIFT key until the red light blinks twice (the red light will blink once then twice).
4. Press **9 9 1**. The red light will blink twice.
5. Next, press **a function**. *
6. Aim the FOCUS 3-MODE at your Television. Now press **PROG+** over and over, in order to scan through the codes available in the memory. **You may have to press this key many times (up to 150 times) so please be patient.**

If you skip past a code, you can go to the previous code(s) by pressing the PROG-key. Remember to keep pointing the FOCUS 3-MODE at your Television while pressing this key. **

7. As soon as you have found an appropriate code, press SHIFT key to store the code.

(*) You can sample all functions (0, 1,2 3, Power, Volume Up, Play Stop and Mute), the last function that was sampled before PROG up/PROG down will be the designated function to send for each PROG up/PROG down key press. If no key is pressed before PROG up/PROG down then the default function will be power.

(**) In each code you can test the following functions: 0, 1,2 3, Power, Volume Up, Play Stop and Mute. After sampling these functions you can continue the search with the previous (PROG down) or next (PROG up) code which will send the function that was originally pressed after 991.

-Most TV's do not switch on pressing the POWER key. Please try pressing a "number" key or the "TV-text off" key to switch your TV back on. -If you cannot control your Television properly, please continue the Search Method, you may be using the wrong Code. -To search for the code for another device follow the instructions above only press the appropriate device key instead of TV during step 2. -If the original remote control of your Video recorder or DVD player does not have a POWER key, press PLAY instead of POWER during step 5.

Code blink out

Once you have Set-Up your FOCUS 3-MODE, you can blink back your Set-up Code for future reference.

Example: to blink out your television code:

1. Press the **TV** key once.
2. Press and hold down SHIFT until the red light blinks twice (the red light will blink once then twice).
3. Press **9 9 0**. The red light will blink twice.
4. For the first digit of your four-digit code, press **1** and count all the red blinks. If there are no blinks, the digit is „0“.
5. For the second digit of your four-digit code, press **2** and count all the red blinks. If there are no blinks, the digit is „0“.
6. For the third digit of your four-digit code, press **3** and count all the red blinks. If there are no blinks, the digit is „0“.
7. For the fourth digit of your four-digit code, press **4** and count all the red blinks. If there are no blinks, the digit is „0“.

Now you have your four-digit code.

-To blink back the code for your other devices, press the appropriate device key during step 1.

Quick Code Reference

Make sure you write down the codes for your devices in the boxes below and in the battery compartment for future easy reference.

Device Type 1 2 3

Volume Punch Through

You may be able to use some functions of your Television, DVD player or the set top box at the same time.

For example: if you are watching a program on your DVD player, you can adjust the volume (a TV function) without pressing the TV mode key on your FOCUS 3-MODE. The table below lists some of the possibilities.

Last Device Mode Key Pressed: You Can Control:

STB TV volume up and down, mute DVD TV volume up and down, mute

To punch through to TV volume while in the DVD or STB mode:

1. Press and hold SHIFT until the red light blinks twice.
2. Press **9 9 3**.
3. Then press the **TV** key and the red light will blink twice.

To cancel the “Volume Punch Through” per mode:

(Example: to cancel the “Volume Punch Through” for the DVD mode)

1. Press **DVD** once.
2. Press and hold down the SHIFT key until the red light blinks twice.
3. Press **9 9 3**.
4. Then press the **Volume (-)** key and the red light will blink four times.

Example: being in DVD mode, you will be able to control VOL+/-or MUTE functions of your DVD (provided it has volume control).

To cancel the „Volume Punch Through“:

1. Press and hold SHIFT until the red light blinks twice.
2. Press **9 9 3**.
3. Press the **Volume (+)** key and the red light will blink four times.

Real Time Macro

You can program your UNIVERSAL FOCUS 3-MODE to issue a sequence of commands at the press of one button. For example, you may want to turn off your TV, DVD and the set top box at the same time. Any sequence you regularly use can be reduced to one keystroke for your convenience. A key that is programmed with a Macro works through all modes (provided it is accessible in that mode). You can install a Macro on any key except for the Mode keys and SHIFT key.

To set up a Macro:

1. Press and hold SHIFT until the red light blinks twice.
2. Press **9 9 5**
3. Press the key to which you want to assign the Macro to
4. Press the command you want program in the macro (up to 8 commands are possible)
5. Press the SHIFT key to store the Macro

To clear a Macro setup:

1. Press and hold SHIFT until the red light blinks twice.
2. Press 9 9 5
3. Press the key to which you had the Macro assigned to
4. Press the SHIFT key to clear the Macro

Feature Reset (980)

The feature reset clears all configuration settings that you programmed with features as Macros and Volume Lock.

1. Press and hold SHIFT until the red light blinks twice.
2. Press 9 8 0
3. A successful reset is indicated when the red light will blink twice, pause and blink twice again.

Master Reset (977)

The master reset clears all configuration settings that you programmed with features as Macros and Volume Lock as well as it clears the programmed device codes. The remote will revert back to the default settings for features and default device codes. As a result the remote will start up in the STB mode.

1. Press and hold SHIFT until the red light blinks twice.
2. Press 9 7 7
3. A successful reset is indicated when the red light blinks twice, pause and blink twice again

Trouble-Shooting

Your brand is not listed in the code section? -Try the search method on previous pages. The FOCUS 3-MODE does not operate your device(s)? -A) Try all the codes listed for your brand. B) Try the search method. The FOCUS 3-MODE is not performing commands properly? -You may be using the wrong code. Try repeating the Direct Set-Up using another code listed under your brand or start the search method over again to locate the proper code. Problems changing channels? -Enter the program number exactly as you would on your original remote.

The FOCUS 3-MODE does not respond after pressing a key? -Make sure you are using new batteries and are aiming the FOCUS 3-MODE at your device. The red light (LED) does not blink when you press a key? -Replace batteries with 2 fresh, new "AA/LR6" alkaline batteries.

LOG IN SCREEN

The first screen to display for the customer is the Login Screen. A customer must select the appropriate User Name and enter a valid password to access any of the services. There are two types of customer accounts: a single master account with full customer access to features and services and one or more sub accounts with access to services as specified by the master account. The structure of the master account and sub accounts provides an account hierarchy for parental control. The master account can add, maintain, and disable sub accounts. The master account is billed any charges relating to services, including services requested by sub accounts.

To Log In Using Your User Name:

Highlight the User Name box on the log in screen. Press OK/Select on remote.

Choose the correct user name and press OK/Select.

Highlight the Password box and press OK/Select.

Use the number keys on the remote to enter in the password. (If using the on screen keyboard, use arrow keys on the remote and press OK/Select on each character to enter the password.)

Once password has been entered, press OK/Select.

Highlight the OK box on the login screen and press OK/Select.

NAVIGATIONAL TOOLBAR (MENU)

Press the Menu button on the remote to display the Navigational Toolbar.

Modes Available From the Navigational Toolbar

1. GUIDE

- Displays the program guide from which customer can browse and select Live, Pay Per View (PPV) and Near Video On Demand (NVOD) broadcasts and access promotional channels. The guide list can be customized in the Favorites Mode.
- To access the Guide Mode, press Menu on remote. Use arrows to highlight the Guide Mode. Press OK/Select.
- Use the arrow keys on the remote to scroll vertically by channel listings or horizontally by time slots. Press OK/Select to tune to the highlighted channel. (You can also tune to a channel using the number keys on the remote.)

2. VAULT

- Displays a list of assets in a customer's storage area based on the customer's current rentals and recordings.
- To access the Vault Mode, press Menu on remote. Use arrows to highlight the Vault Mode. Press OK/Select.

3. SETTINGS

- Provides customers access to work with default account preferences.
- To access the Settings Mode, press Menu on remote. Use arrows to highlight the Settings Mode. Press OK/Select.
- Enter Password. Press OK/Select. On the settings screen, there are four options to choose from:

a. Preferences

Allows Master account to set Parental Controls, Pay Per View limits, Caller ID display and Auto Tune timing.

Use the arrow keys to highlight desired function. Press OK/Select to enable / disable features, or to display drop down options.

b. Users

Allows the Master account to create Sub accounts, assign Login IDs and Passwords and set Parental Controls for Master and Sub accounts.

Use the arrow keys to highlight desired function. Press OK/Select to enable / disable feature, add, change, delete information or create settings.

c. Packages

Displays customer's current channel packages and prices.

NAVIGATIONAL TOOLBAR continued

d. Billing

- The Master account can view billing-related information displaying a list of all accounts with corresponding service descriptions, dates and prices. Charges incurred by Sub accounts are billed to the Master account.

4. FAVORITES

- Allows you to customize the guide listing to show **all** available channels, only **Subscribed** channels, or a list of selected favorite channels.
- To access the Favorites Mode, press Menu on remote. Use arrows to highlight the Favorites Mode. Press OK/Select.
- Use arrow keys to highlight desired function. Press OK/Select.
- Use arrow keys to select list name. Use number keys to name the list. (Holding down a number key on the remote will display alpha lists)
- Use arrow keys to navigate through pages of channel lists. Press OK/Select to check or uncheck channels to include / exclude from channel list.
- Use arrow keys to highlight done. Press OK/Select.

5. SEARCH

- Displays a search option for customers to search for their favorite program or to locate specific titles.
- To access the Search Mode, press Menu on remote. Use arrows to highlight the Search Mode. Press OK/Select.
- Press OK/Select in Text Box. A virtual keyboard will appear. Use the arrow keys and OK/Select for each letter to spell out the program search. Highlight done and press OK/Select.
- Highlight Search option. Press OK/Select.
- Highlight Extended or Quick Search. Press OK/Select.

6. SIGN OUT

- Provides security for Master and Sub account viewing by requiring a valid password be used to access viewing.

TROUBLESHOOTING

- You can correct most problems you have with your product by consulting the following troubleshooting list. For service, please contact your service provider.

➤ **DECODER (SET TOP BOX) PROBLEMS**

- ✓ **Set Top Box won't turn on:**
 - Press STB on the remote. Then push the power button.
 - Check all connections & power supply.
 - Check remote control.
- ✓ **Set Top Box appears to be locked up:**
 - Unplug only the power connection from the back of the Set Top Box. Wait 10 seconds. Power connection is the one that is plugged into the electric outlet.
 - Reconnect. Unit will reboot.
 - Verify that the modem light is on. If the modem light is off, there may be a broken connection to the service provider or service may be momentarily unavailable. Contact your service provider.
- ✓ **No Sound, Picture Okay:**
 - The sound may be muted. Press the Volume Up button or Mute button to restore sound.
 - If using a standard video, S-video, or component video connection, remember to also connect the set top box's L and R Audio Out Jacks to the component's L and R Audio In jacks.
- ✓ **No Picture, No Sound but Set Top Box is Turned On:**
 - If your Set Top Box is connected to the Cable/Antenna jack on your TV with a coaxial cable, tune the TV to channel 3 or 4.
 - If your Set Top Box is connected to your TV with Audio/Video cables, tune your TV to the appropriate Video Input Channel.
- ✓ **Sound Okay, Picture Poor:**
 - Check connections. Make sure all of the cables are firmly connected.
 - Change the channel.
- ✓ **No Connection After More Than Five Minutes:**
 - Make sure all connections are secure and try connecting to your service provider again. If you still have problems connecting to the network, contact your service provider.
- ✓ **One Set Top Box Doesn't Work, But One Does:**
 - Verify that the indicator light is lit on the set top box. If the indicator light is off, check your connection from the modem to the set top box.
- ✓ **"Signal Is Temporarily Unavailable" Appears:**
 - Change channels to see if it is a station problem. If it appears on more than one channel, there may be a problem with the signal. Contact your service provider.

TROUBLESHOOTING continued

- ✓ **The Set Top Box Was Working Then “Signal Is Temporarily Unavailable” Appears:**
 - Momentarily unplugging the modem will cause all set top boxes to lose signal during a reboot.
- ✓ **While Connecting, “Contacting The Network” Appears For A Long Time:**
 - Verify the modem indicator light is on. If the modem light is off, there may be a broken connection to the service provider or service may be momentarily unavailable. Please contact your service provider.

➤ **REMOTE CONTROL PROBLEMS**

- ✓ Something might be between the remote and the remote sensor on the component. Make sure there is a clear path.
- ✓ Make sure the remote is aimed directly at the component that you are trying to operate.
- ✓ Make sure the remote is in set top box mode. Press the STB button to operate the set top box.
- ✓ Check your batteries in the remote. They may be weak, dead or installed incorrectly. Put new batteries in the remote.
- ✓ Note: If you remove the batteries, you may have to reprogram the remote to operate the components.
- ✓ You might need to drain the remote’s microprocessor:
 - Remove batteries and press the number 1 for 60 seconds.
 - Release the number 1 button and replace the batteries.
 - If necessary, program the remote again.

➤ **CARE AND CLEANING**

CAUTION: Unplug your set top box before cleaning.

- You can clean the unit as required, using a soft lint-free cloth. Be sure to occasionally dust the ventilation slots in the cabinet to help assure adequate ventilation.
- Never use strong cleaning agents, such as ammonia-based cleaners, or abrasive powder. These types of cleaners will damage the unit.
- Avoid placing drinks or vases with water on top of the unit. This could increase the risk of fire or shock hazard or damage to the set top box.